



9400 Series – Guided Wave Radar (GWR) Level Sender

Application

The 9400 series guided wave radar level transmitter is a breakthrough in cost effective very high accuracy, very high resolution liquid level sensing for heavy duty applications. Rochester Gauges' GWR level sensor is the culmination of years of research into micropower impulse radar, time domain reflectometry and equivalent time sampling.

Rochester Gauges Model 9400 liquid level sensor is used to monitor liquids such as fuels, chemicals, water, coolant, lubricants and other materials. The device is capable of maintaining very accurate level readings regardless of liquid. The 9400 can optionally be configured to accurately measure both fuel level and the level of dissimilar materials, such as water/fuel interface.

The device emits a series of electromagnetic pulses down the sensor probe. Liquid/air interface, and dissimilar liquid interfaces provide a change in the characteristic impedance of the sensor probe, and create a reflection of the pulse. The time-of-flight of the reflected pulses is measured, and the liquid and interface levels are calculated.

General Information & Features

- **Active Sensing Range** 35mm to 1000mm from flange
- **Housing Size** 45mm (Height) x 67mm (diameter)
- **Connector** Configurable depending on output requirement
- **Operating Temperature Range** -40°C to +85°C
- **Water and Dust Sealing** IP69K
- **Maximum Tank Pressure** 15 PSI
- **Shock** ISO 16750-3
- **Vibration** BS EN 60068-2-64: 1993 IEC 60068-2. Up to 500mm
- **Drop** ISO 16750-3
- **Surface Resistance** ISO 16750-3
- **Chemical Resistance** ISO 16750-5
- **Corrosion Resistance** VDA 621-415, DIN EN ISO 16270-2, DIN EN ISO 9227
- **Corrosive Gas Resistance** DIN 50018

* Materials and specifications are subject to change without notice.



• See reverse side for dimensional data, materials of construction, performance, and advice on how to order.



9400 Series – Guided Wave Radar (GWR) Level Sender

Electrical Specifications

- **Supply Voltage** 9-36 V_{DC} or 5V_{DC} regulated
- **Supply Current** 35mA average
- **Superimposed AC over DC** ISO 16750-2
- **Supply Voltage Drop** ISO 16750-2 Section 4.6
- **EMC/EMI** UN ECE R10 revision 5

Construction*

- **Housing** Die Cast Low Copper Aluminum
- **Sensor Tube** Extruded Low Copper Aluminum
- **Wetted Materials** Low Copper Aluminum, Buna Nitrile (or Viton), FR-4
- **Mounting Configuration** Configurable including 4-bolt, 5-bolt SAE and 6-bolt

*Materials and specifications are subject to change without notice. Pressure ratings subject to change due to temperature and other environmental considerations.

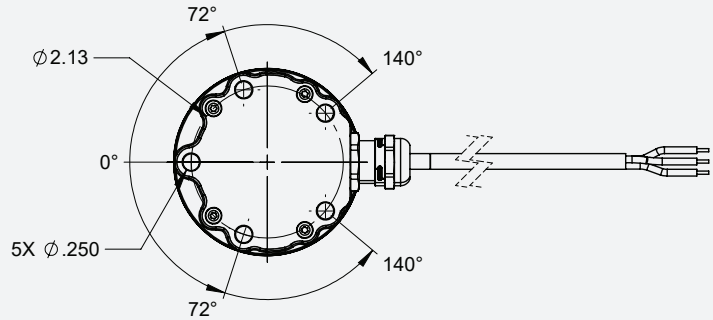

Output Specifications

- **Output Protocol** Analog – Voltage, PWM; Digital – LIN, CAN; Optional programmable alarm output
- **Accuracy** ±2.0% of span max (including nonlinearity, hysteresis, temperature effects).
- **Resolution** 1mm

