



**ROCHESTER
GAUGES, INC.**

TwinSite™ Switch

VD002

ISO 9001:2008 CERTIFIED

Application

Rochester TwinSite® switches are utilized where direct-reading plus electrical contact closure is required. Models are available to fit all Rochester Junior® and Senior® gauges with large magnets.

Note: Some applications require use only with intrinsically-safe circuits.

General Information & Features

These TwinSite® Switches use a nickel-plated copper switch base in conjunction with a multi-fingered contact arrangement. This unique combination in the liquid level-gauge industry provides better inherent accuracy and reliability.

A typical switch would be open from full down to one-eighth and closed from one-eighth to empty. The built-in connector mates with a standard Packard- sealed connector for easy installation and reliable connections. The connector and harness assembly, with 18" long wires, must be ordered separately under part number 0154S00023.



**TwinSite™
Switch**

01/29/10

See reverse side for dimensional data, materials of construction, performance, and advice on how to order.

The Measure of Excellence

VD002**TwinSite™ Switch**

[METRIC]

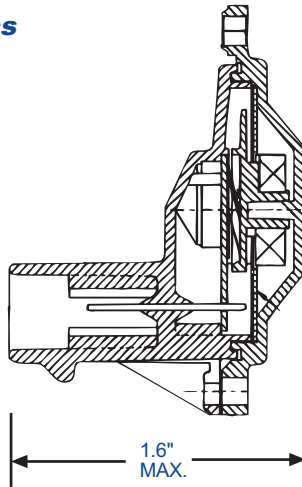
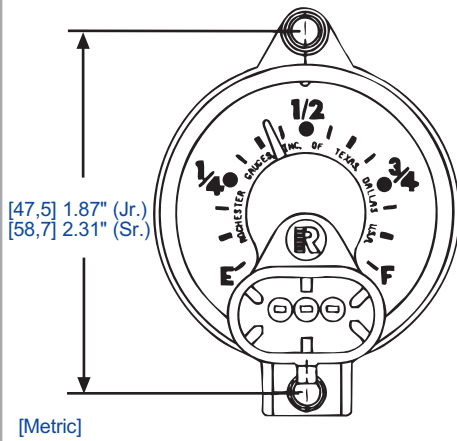
Envelope Dimensions

With Mating connector installed, the height is 2" [50,8] plus wire clearance.

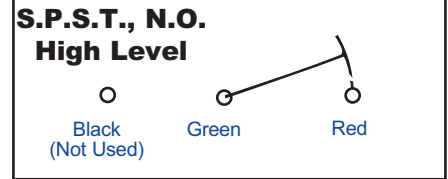
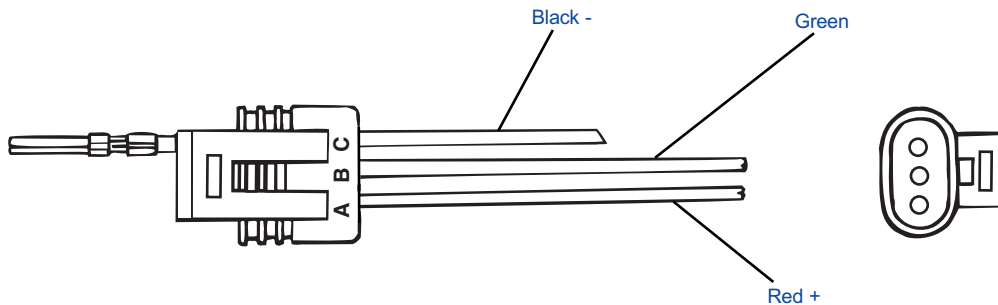
Wiring Diagram**Mating Connector****General Specifications*****Contact Resistance**

0.2 ohm maximum

Rotational Life

Up to 50,000 cycles

Operating Temperature

-40 to 70C, -40°F to 158°F

Power Rating

2.4 watts

Repeatability

0.5%

Accuracy

±3%

Maximum Current

1.4 Watts inductive or 4 watts resistive at 24 volts or less
D.C., 1.6 watts inductive or resistive at 24 VAC or less.

Materials Of Construction***Switch Element**

Nickel-plated copper.

Substrate

Glass epoxy.

Crystal and Case

Polycarbonate, ultrasonically sealed.

Pointer

Acetal

How To Order

Refer to Price List D6200 for LP-Gas switches and Price List P6200 for Industrial switches.

* Materials and specifications are subject to change without notice.
Pressure ratings subject to change due to temperature and other environmental considerations.

01/29/10