

**The Eliminator™
Rotogauge Replacement
For LP Gas & NH₃ Service**

**P6293
Series**

Application

The Eliminator™ direct-reading float gauge is a direct replacement for 1" NPT rotary-type dip-tube gauges in LP and NH₃ storage tanks. These gauges are designed for larger tanks up to 84" [2134mm] in diameter. The Eliminator™ is not intended for use in filling tanks - its use is restricted to tanks with fixed liquid level gauges, used to determine when the maximum fill level has been reached. The eliminator can be used in mobile applications up to 72" [1828mm] in diameter.

How To Do The Conversion

1. After the storage tank has been evacuated, remove the rotary gauge from the 1" NPT opening at the centerline of the head. Clean and re-tap the female threads.
2. Remove the two screws from the bezel. Put the bezel, screws and dial chamber aside for the moment. Remove the four mounting screws holding the gauge head to the adapter.
3. Insert the lower portion of the replacement gauge, including the float bulb, float arm, gear housing and counterbalance, into the tank opening.
4. Apply three wraps of 1/2" [12mm] wide Teflon tape, or other suitable thread sealant, to the 1" NPT threads on the steel adapter through which the gauge support passes.
5. Screw the adapter into the tank opening to achieve a leak-tight joint, and align the gauge mounting holes in the horizontal plane.
6. Using the gasket and four mounting screws supplied, attach the gauge to the adapter fingertight. Be sure the gauge is right side up, the bracket tab for locating dial chamber should be on the right. Torque the mounting screws evenly to 140/150 lb.in., [16,4Nm] using a cross pattern.
7. Reattach the 4" dial chamber and bezel to the Senior™ gauge head brackets using the two screws supplied.
8. If you end up with the dial chamber upside down, you cannot solve the problem by rotating the bracket. You must rotate the entire gauge 180°.

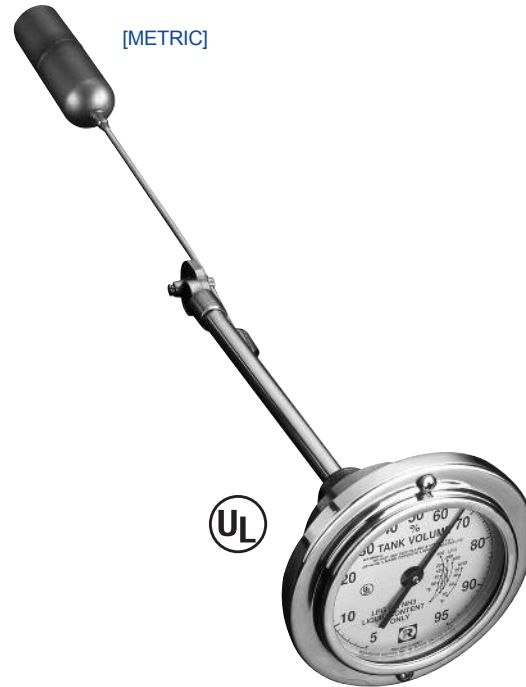

Part #	Fits Tank Size I.D.
Stationary P6293-R4400 Mobile	Up Thru 44" [1210]
Stationary P6293-R6000 Mobile	44.1" Thru 60" [1210] - [1524]
Stationary P6293-R7200	60.1" Thru 72" [1524] - [1829]
Mobile PM6293-R7200	60" Thru 72" [1524] - [1829]
Stationary P6293-R8400	72.1" Thru 84" [1829] - [2134]

The Eliminator™ Rotogauge Replacement

Any Eliminator installed in a tank greater than 44" is excluded from the Rochester Gauge Limited Warranty.

P6293 Series

The Eliminator™ Rotogauge Replacement For LP Gas & NH₃ Service

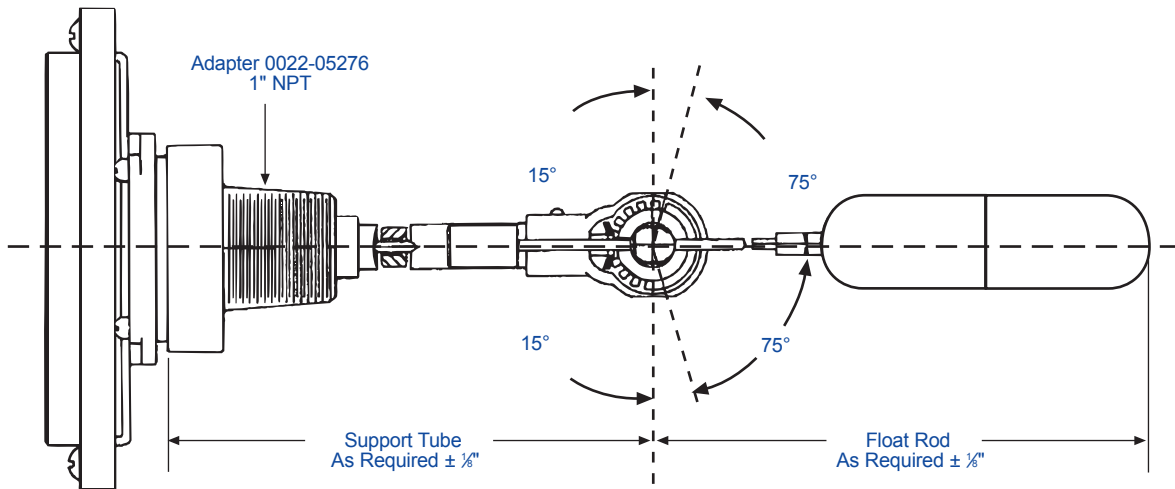

Materials of Construction*

Head, Gears, Gear Housing, Cross Stud, Bearings & Float

Stainless steel.

Centershaft, Float Rod, & Support Tube

Stainless steel.

Drive Magnet

Alnico.

Gasket

Spiral wound, teflon filled, stainless steel.

Adapter

Cold-rolled steel.

Counterweight

Stainless steel.

When ordering, specify:

1. Model number.
2. Tank I.D.
3. Shape of the head.

WARNING: Carefully ensure that gauge and adapter are adequately protected from damage that might cause leakage of tank contents.

* Materials and specifications are subject to change without notice.
Pressure ratings subject to change due to temperature and other environmental considerations.

08/19/11