



ISO 9001:2008 CERTIFIED

READ COMPLETELY BEFORE ATTEMPTING INSTALLATION*

WARNING: IMPROPER INSTALLATION OR USE OF THIS PRODUCT MAY CAUSE SERIOUS INJURY OR PROPERTY DAMAGE.

These instructions are prepared to assist tradesmen and others qualified to service liquid storage tank equipment. Consumers are not qualified to perform the installation described below. If you have any questions concerning installation or operation of the gauge, contact Rochester Gauges or one of our authorized distributors for assistance. This document is not instructions for tank filling.

BE SURE YOU HAVE THE PROPER GAUGE.

IS THE GAUGE RIGHT FOR YOUR APPLICATION?

Gauges should only be installed in applications recommended by the manufacturer. Verify that the gauge is the proper gauge for your application prior to attempting installation.

The float may or may not have a counterbalance depending on the intended application. Applications for light specific gravity liquids or large tanks normally require counterbalancing of the float.

The gauge, and coupling must be constructed of materials compatible with the liquid to be measured and the service environment. The float and head must be adequately rated for your specific pressure and temperature service.

IS THE GAUGE THE PROPER SIZE?

As a general rule, the float pivot point should be on the horizontal centerline of the tank when installed. The float length dimension (measured from the float pivot point to the end of the float) should be proportional to the inside tank height and is usually slightly less than 1/2 of the vertical inside height of the tank. Gauges can be constructed for side, top or angle mounting but must be installed in the position for which they are constructed. Hold the gauge by the support (see Figure A) in the intended mounting attitude and operate the float to see if it is correct for your application (see Figure B).

CAUTION: Improper gauge or dial selection or application may result in inaccurate readings. Release of tank contents as well as damage to equipment and safety hazard may result if tank is overfilled. Fuel exhaustion may occur if tank contents are less than indicated. LP Gas & NH₃ gauge dials require an appropriate temperature chart.

WARNING: Determine and install the appropriate gauge based on system requirements. The information contained herein is intended for guideline use only and the suitability of any part for a particular application must be determined by the user prior to installation. Improper application or installation may result in seal failure, subsequent release of tank contents and serious injury and or property damage.

WARNING: This gauge is not a substitute for a fixed liquid level gauge or weight measurement device, which may be required for filling.

GAUGE REMOVAL WARNING: Should it appear necessary, for any reason, to remove the gauge from the tank, do not attempt removal unless under competent supervision with all due precautions taken against the hazards of released liquid or high pressure and/or flammable gas.

HAZARDS: Even if the gauge registers empty, the tank may contain hazardous quantities of flammable, pressurized liquid and vapor. A hazard of fire or explosion may exist if proper methods are not used when removing or installing gauges or other pressure containing fittings.

* Materials and specifications are subject to change without notice. Pressure ratings subject to change due to temperature and other environmental considerations.

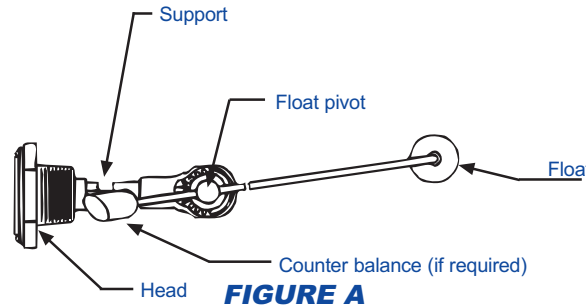

FIGURE A

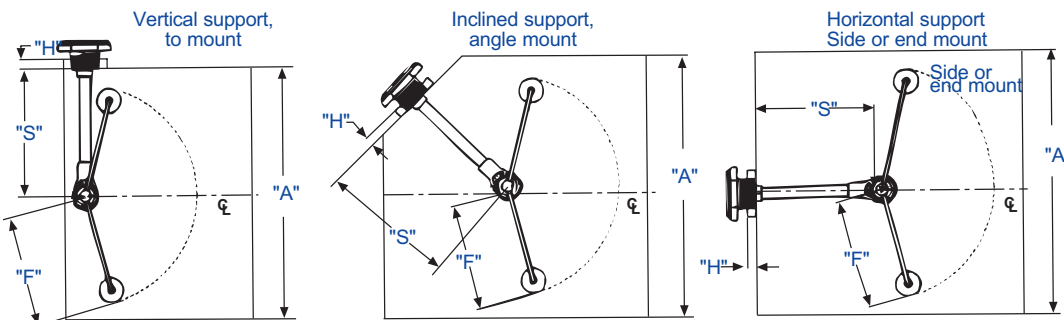
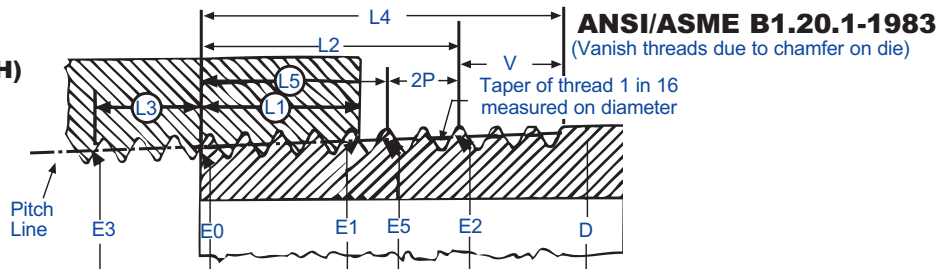

FIGURE B

**Threaded Gauge
Installation Instructions**

[METRIC]

**An American National Standard
Pipe Threads, General Purpose (INCH)**



Basic dimensions of American National Standard Taper Pipe Thread. NPT¹

Nominal Pipe Size (NPT)	O.D. of Pipe (D)	Threads/in. (n)	Pitch of Thread (P)	Pitch dia. at beginning of External Thread (E)	Handtight Engagement			Effective Thread, External		
					Length ² (L ₁)		Dia. ³ (E)	Length ⁴ (L ₂)		Dia. (E)
					inch	Threads		inch	Threads	
1	2	3	4	5	6	7	8	9	10	11
1/2	0.840	14	0.07143	0.75843	0.320	4.48	0.77843	0.5337	7.47	0.79179
3/4	1.050			0.96768	0.339	4.75	0.98887	0.5457	7.64	1.00179
1	1.315	11.5	0.08696	1.21363	0.400	4.60	1.23863	0.6828	7.85	1.25630
1 1/4	1.660			1.55713	0.420	4.83	1.58338	0.7068	8.13	1.60130
1 1/2	1.900			1.79609	0.420	4.83	1.82234	0.7235	8.32	1.84130
2	2.375			2.26902	0.436	5.01	2.29627	0.7565	8.70	2.31630

Nominal Pipe Size (NPT)	Length, L ₁ Plane to L ₂ Plane External Thread (L ₂ -L ₁)		Wrench Make-Up Length for Internal Thread ⁷			Vanish Thread (V)		Overall ⁸ Length External Thread (L ₄)	Nominal Complete External Threads ⁵		Height of Thread (h)	Increase in Dia./ Thread (0.0625/ n)	Basic ⁶ Minor Dia. at Small End of Pipe (K ₀)
	inch	Threads	Length (L ₃)		Dia. (E)	inch	Threads		Length (L ₅)	Dia. (E ₅)			
			inch	Threads									
1	12	13	14	15	16	17	18	19	20	21	22	23	24
1/2	0.2137	2.99	0.2143	3	0.74504	0.2478	3.47	0.7815	0.3909	0.78286	0.05714	0.00446	0.7013
3/4	0.2067	2.89			0.95429			0.7935	0.4029	0.99286			0.9105
1	0.2828	3.25	0.2609	3	1.19733	0.3017	3.47	0.9845	0.5089	1.24543	0.06957	0.00543	1.1441
1 1/4	0.2868	3.30			1.54083			1.0085	0.5329	1.59043			1.4876
1 1/2	0.3035	3.49			1.77978			1.0252	0.5496	1.83043			1.7265
2	0.3205	3.69			2.25272			1.0582	0.5826	2.30543			2.1995

Notes:

- The basic dimensions of the American National Standard Taper Pipe Thread are given in inches to four or five decimal places. While this implies a greater degree of precision than is ordinarily attained, these dimensions are the basis of gauge dimensions and are so expressed for the purpose of eliminating errors in computations.
- Also the length of thin ring gauge and length from gauging notch to small end of plug gauge.
- Also pitch diameter at gauging notch (handtight plane).
- Also length of plug gauge.
- The length L₅ from the end of the pipe determines the plane beyond which the thread form is incomplete at the crest. The next two threads are complete at the root. At this plane the cone formed by the crests of the thread intersects the cylinder forming the external surface of the pipe. L₅=L₂-2p
- Given as information for use in selecting tap drills.
- Military Specification MIL-P-7105 gives the wrench make-up as three threads for sizes 3 and smaller.
- Reference dimension.

Installation

- Gauges are normally fastened to tank using a coupling which has previously been welded into the tank. Check coupling with certified thread plug gage for correct dimensions after welding.
- Apply appropriate pipe thread compound to gauge mounting threads.
- Carefully insert float into coupling and work gauge's gear housing and support through coupling being careful not to bend or damage them.
- Install gauge at 30 rpm or less
- Torque head to range listed below.
- Align head for proper orientation of float inside of tank.
- Leak test.
- Ask for appropriate procedure listed below for more detailed information.

CAUTION: Do not over torque. Do not re-torque later unless leaking. Over tightening may cause damage to head and threads.

NOTE: See 115-794 for replacement dial instructions.

Gauge Thread	Dry Torque (ft. lbs.)	Procedure	Gauge Thread	Dry Torque (ft. lbs.)	Procedure
1 1/2" NPT	125-225 [170-305 Nm]	-	1 1/4" NPT	100-200 [136-270 Nm]	DS-322
1" NPT	75-150 [102-200 Nm]	DS-629	3/4" NPT	50-100 [68-136 Nm]	DS-996
1/2" NPT	30-80 [40-108 Nm]	-	-	-	-