

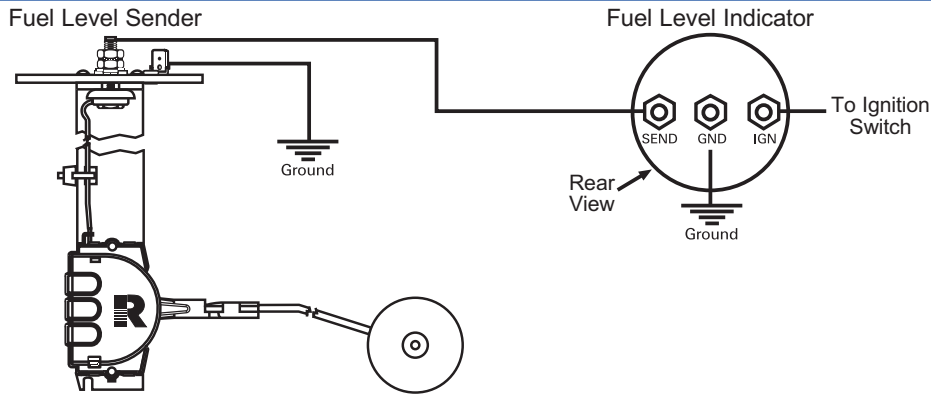

ISO 9001:2008 CERTIFIED

**CAUTION:** Read Completely Before Attempting Installation



### Installation

#### Top Mounted

Install using a nitrile rubber gasket. Use # 10-24 screws (or equivalent) to secure sender head to tank. Torque screws to 20-25 in.-lbs. [2,3 to 2,9 N-m] torque.

Fuel Level Senders		
Part #	Ohms	Application
8340, 9340	Various	Marine, Industrial, Adjustable
8341, 9341		
8349		

#### Side or Bottom Mounted

See MS-514

### Sender Electrical Connections

Usually the mounting screws ground sender head to tank. However, in some cases, it may be necessary to connect head to a suitable grounding point. System voltage should not be applied to sender terminal. The excitation from fuel level indicator is current and voltage limited, and incapable of causing ignition of fuel vapor when sender lead wire is shorted to ground. Care must be taken to ensure that the bottom nut on terminal stud is not disturbed when electrical connection is made. The bottom terminal stud nut torque is factory set to provide the correct terminal stud seal preload.

#### Electrical Terminals Should Be Tightened As Follows

#6	6 in.-lb.
#8	12 in.-lb.
#10	14 in.-lb.

### Wiring

1. Turn ignition switch off.
2. Using insulated 16-gauge wire, connect the ignition terminal on the indicator to a battery positive source, usually parallel with the ignition circuit.\*
3. Using insulated 16-gauge wire connect center terminal on the sender to sender terminal on a matched indicator.
4. Using insulated 16-gauge wire establish a ground connection from the other terminal on sender to ground terminal on the indicator.
5. Establish ground connection between indicator ground terminal and ground.

\*NOTE: Do not connect the indicator directly to the battery; connect through a fuse box.

Tank Flange Detail  
See Rochester MS-514 For Details

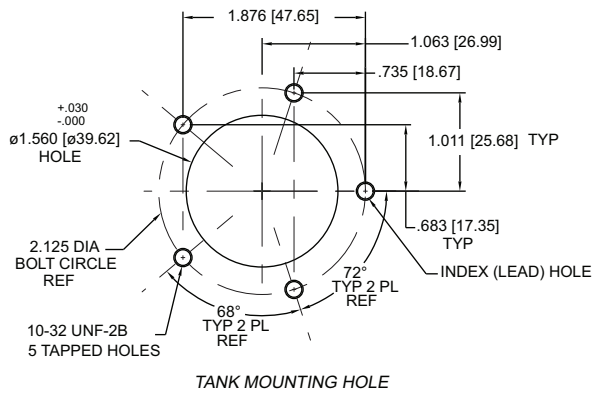

### Maintenance & Quality Assurance Considerations

Since this is not a metal to metal joint, the torque and screw clamp load will naturally relax as the gasket flows to a normal condition.

**CAUTION: Do not over-torque. Do not re-torque.** Excessive torque/or re-torquing will warp or distort sender head. The gaskets underneath sender head that are warped during installation or re-torquing are probably over-compressed and thus, overstressed. Pinching or over-compression of gaskets can dramatically reduce their service-life and may result in failure (leakage) in service.

### Sender Removal Warning

Should it appear necessary, for any reason, to remove a sender from the tank, do not attempt removal unless under competent supervision with all due precautions taken against the hazards of escaping flammable liquid or vapor.

NOTE: For Twinsite™ installation see DS-923.

# Instructions For Installing Rochester 8300 and 9300 Series Fuel Level Senders

**Step 1.** (This usually solves the problem)

Before you do anything else, check for defective wiring or grounds as this is the most common cause of indicator system failures. Inspect all wiring and terminals. Also look for corrosion on fuel tank ground connection.

**Step 2.**

If pointer in indicator does not move when ignition switch is turned on, check to see that voltage is actually being carried from the ignition switch to the IGN terminal on the indicator. Also check to assure that paint or corrosion does not prevent proper indicator ground.

**Step 3.**

If the indicator reading is not accurate with tank level, use a resistance substitution device to verify that the indicator resistance input requirements are the same as the sender output resistance. They must be matched to get an accurate reading.

**Safety Test Circuit For Fuel Level Indicators**

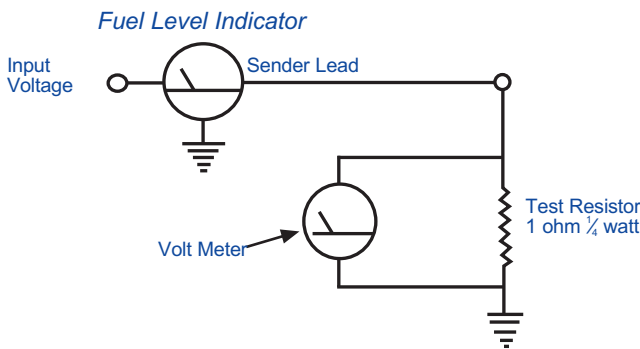

Fuel Level Indicator Reading (At Panel)	Possible Cause
<b>No Indication</b> (Pointer does not move when power is turned on)	1. Empty fuel tank. 2. No voltage to indicator because of broken or disconnected wire. 3. Indicator not grounded. 4. Indicator defective.
<b>Erratic Reading</b> (Jumpy)	1. Loose connection. 2. Defective sender.
<b>Inaccurate Reading</b>	1. Defective sender. 2. Indicator incompatible with sender.
<b>0 to 90 OHM Systems &amp; Others With Low Resistance At Empty</b>	
<b>Indicator reads FULL at all times</b>	1. Wire from sender broken. 2. Sender not properly grounded. 3. Defective sender.
<b>Indicator reads EMPTY at all times</b>	Grounded wire between sender & indicator.
<b>240 to 30 OHM Systems &amp; Others With High Resistance At Empty</b>	
<b>Indicator reads EMPTY at all times</b>	1. Wire from sender broken. 2. Sender not properly grounded. 3. Defective sender.
<b>Indicator reads FULL at all times</b>	Grounded wire between sender & indicator.

**CAUTION:** Rochester fuel level senders will be destroyed and Indicators may be damaged if 12 volt wire touches the sender terminal. Voltage to energize the sender must come through the indicator from the terminal marked SEND or SNDR.

**WARNING:** With ignition switch on, the voltage indicated across test resistor (1 ohm) must not exceed 0.25 volts. The current through sender must not exceed 0.25 amps. Excessive current or voltage could ignite fuel vapors and cause an explosion.

For complete information, refer to UL # 913.

Improper sender or indicator selection or application may result in inaccurate readings. Release of tank contents as well as damage to equipment and safety hazard may result if tank is overfilled. Fuel exhaustion may occur if tank contents are less than indicated.

**WARNING:** These instructions were prepared to assist tradesmen and others generally familiar with this type of equipment. Consumers are not qualified to perform installations. If you have any questions about these procedures, please contact Rochester Gauges for assistance.

There are several different styles of sending units. The differences are both external and internal. Be sure you have the correct replacement part number before installation.

**WARNING:** Materials and specifications are subject to change without notice.  
Pressure ratings subject to change due to temperature and other environmental considerations.