



ISO 9001:2000 REGISTERED

General Information & Features*

Rochester liquid-level switches utilize magnetic reed switches hermetically sealed inside capsules. Depending upon the switch model, the reed switch may act alone or trigger solid-state devices at the required point through magnetic actuation by a high-strength drive magnet located in the head of the liquid-level gauge.



Mark	Part #	Calib.	Switch	Max. Volts	Max. Amps	Max Watts	Construction	Application
5S23	5023S00778	LH	S.P.S.T.	140 VAC 50 VDC	0.5 resistive	10	Reed Switch only	Low current control circuit
5S254	5254S00778	RH		240 VAC 500 VDC	0.5 small inductive		High voltage Reed Switch	
5S255	5255S00778							
5S24	5024S00778	LH or RH	S.P.D.T.	125 VAC 28 VDC	0.25 resistive	3	Special S.P.D.T. Reed Switch	High/low signal with very narrow overlap
5S55	5055S00778	LH	S.P.S.T.	120 VAC AC Only	2.0 resistive	150	Reed Switch with Triac and MDV transient suppression	High current control circuit
5S74	5074S00778				1.0 inductive	75	Same as 5S55 except with low Amp Triac	Medium current control circuit
5S248	5248S00778	RH		240 VAC AC Only	2.0 inductive	300 at 230 V	Similar to 5S55 except with HV Reed Switch and M.O.V. transient suppression	Low current control circuit
5S80	5080S00778	LH						
5S149	5149S00778	LH	240 VAC AC Only	1.0 inductive	150 at 230 V	Same as 5S89 except high voltage Reed Switch and Triac	Medium current high differential	

* Materials and specifications are subject to change without notice.
Pressure ratings subject to change due to temperature and other environmental considerations.

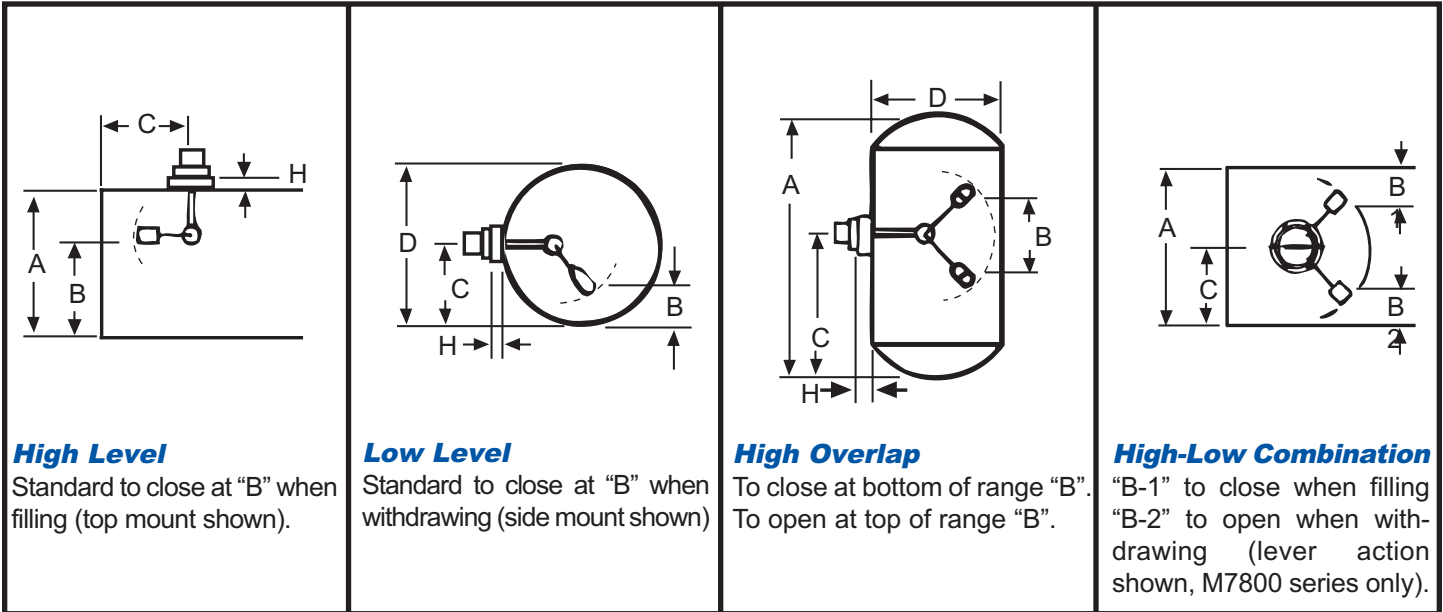

Notes

The liquid-level switches shown on the preceding page are suitable for use with the following Rochester switch-gauges:

Gauge #			
M6250	6453	7553	L8453
LM6253	L6453	8450	8550
M6253	7550	8453	8553

All standard switch gauges have Senior™ heads for mounting on a 2 1/2" [63, 5 mm] bolt circle, and are furnished complete with four mounting screws and a mounting gasket. See Rochester brochure, 22 Series Adapters, for the available mating-tank adapters.

All LH calibrated switches are mechanically and magnetically interchangeable with all other LH calibrated switches. The same is true for RH calibrated switches. All "AC only" switches are intended for AC only as these devices will open circuit only when the voltage cycle passes through zero.

How To Order

Select the switch and switchgauge most suitable for our application. Typical applications are shown above.

When ordering, specify:

1. A, B, C, D, and H tank diameters.
2. Type of liquid and working pressure.
3. Electrical requirements and type of operation (to close or open at special level).

In all cases, a sketch or drawing of your particular application will help ensure your needs will be accurately and completely understood.

Note: For installation instructions see DS-889 (data sheet).