

8341-7000 Series Senders ONLY†

NOTE: The given cut-off length will allow a minimum of 1" clearance to the bottom of tank at empty.

TANK DEPTH	DISTANCE FROM END OF WIRE TO FLOAT ROD 90° BEND POINT
4" to 4-1/2"	Order p/n 0020-00588
4-1/2" to 5"	Order p/n 0020-00586
5-1/4" to 5-3/4"	Order p/n 0020-00587
6"	3" *
6-1/2"	3-1/2" *
7"	4" *
7-1/2"	4-1/2" *
8"	5" *
8-1/2"	5-1/2" *
9"	6-1/8" *
9-1/2"	6-5/8" *
10"	7-1/8" *
10-1/2"	7-5/8" *
11"	8-1/8" *
11-1/2"	8-3/4" *
12"	8-3/4"
12-1/2"	9-1/4"
13"	9-3/4"
13-1/2"	10-1/4"
14"	10-7/8"
14-1/2"	11-3/8"
15"	11-7/8"
15-1/2"	12-3/8"
16"	12-7/8"
16-1/2"	13-1/2"
17"	14"
17-1/2"	14-1/2"
18"	15"
18-1/2"	15-1/2"
19"	16" **
19-1/2"	16-5/8"

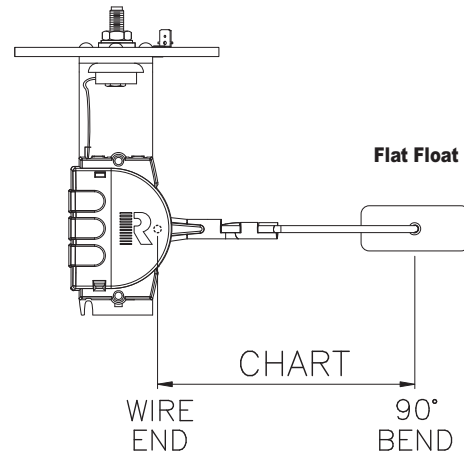

FOR 72.5° FLOAT TRAVEL

***NOTE: 1/2" CLEARANCE @ E**

****NOTE: FLAT FLOAT IS APPROX. 80% SUBMERGED**

† Materials and specifications subject to change without notice.
Ratings subject to change due to temperature and other environmental considerations.

MATERIAL	PAGE 4 OF 4	DRAWING NUMBER DS-1235										
----------	-------------	---------------------------	--	--	--	--	--	--	--	--	--	--

CENTER STUD

#10-32 THREADED STUD

.250" SPADE TERMINAL

33 OHMS (OR 90 OHMS) FLOAT AT FULL

240 OHMS (OR 0 OHMS) FLOAT AT EMPTY

72.5°

20° F

52.5° E

WARNING: CONNECT CENTER TERMINAL TO A 240-33 OHM (OR 0-90 OHM) FUEL LEVEL INDICATOR ONLY. DO NOT CONNECT CENTER TERMINAL TO PRIMARY VOLTAGE. FIRE HAZARD AND DAMAGE FROM SHORT CIRCUIT MAY RESULT IF IGNITION WIRE TOUCHES EITHER CENTER TERMINAL OR WIRE THAT IS CONNECTED TO CENTER TERMINAL.

CAUTION: THESE INSTRUCTIONS (DS-1235) ARE INTENDED FOR NEW INSTALLATIONS AND NOT FOR REPLACEMENT INSTALLATIONS.

A	ADDED CAUTION NOTE.	8981	9/1/99	B	PAGE 4 OF 4 WAS 3 OF 3	15160	6/12/03	C	ADD 0-90 OHM REF.	19412	9/5/06
LET	REVISIONS	E.R.#	DATE	LET	REVISIONS	E.R.#	DATE	LET	REVISIONS	E.R.#	DATE
TOLERANCES NOT SHOWN	$\pm .010$	$\pm .005$	ANGLES $\pm 1^\circ$	MAT'L: COMMERCIAL TOLERANCES	DO NOT SCALE DRAWING	SUPERSEDES	DRAWN <i>RECH</i>	CHK.	REVISIONS	E.R.#	USED ON
ROCHESTER GAUGES, INC., DALLAS, TEXAS, U.S.A.				OF TEXAS		SCALE 1/2		DATE 3/8/99		DRAWING NUMBER DS-1235	

05/01/09