



**ROCHESTER
GAUGES, INC.**

ISO 9001:2008 CERTIFIED

Magnetic Liquid-Level Gauges

8200

Magnetic Liquid-Level Gauges

Application

The brass and stainless-steel construction of the 8200 Series spiral gauge makes it suitable for use in marine applications and in measuring levels of water, oil or fuel. They are also used in a variety of construction and maintenance vehicles such as road sweepers and water spray trucks.

General Information & Features

The Model 8240 spiral gauge incorporates a strong nickel-plated Alnico magnet. The magnet is capable of driving a Twinsite™ sender that sends an electrical signal to a remote receiver and provides a direct, fractional reading.

The model 8260 spiral gauge is supplied with an easy-to-read side-view fractional dial. The model 8280 spiral gauge is equipped with a standard top reading fractional dial.

All 8200 Series spiral gauges have a 1½" MNPT tank connection, and are suitable for tank pressures up to 25 PSIG [1,7 Bar] maximum. They are designed for top mounting only in tanks up to 36" [914 mm] deep and some models are UL listed for flammable liquids.

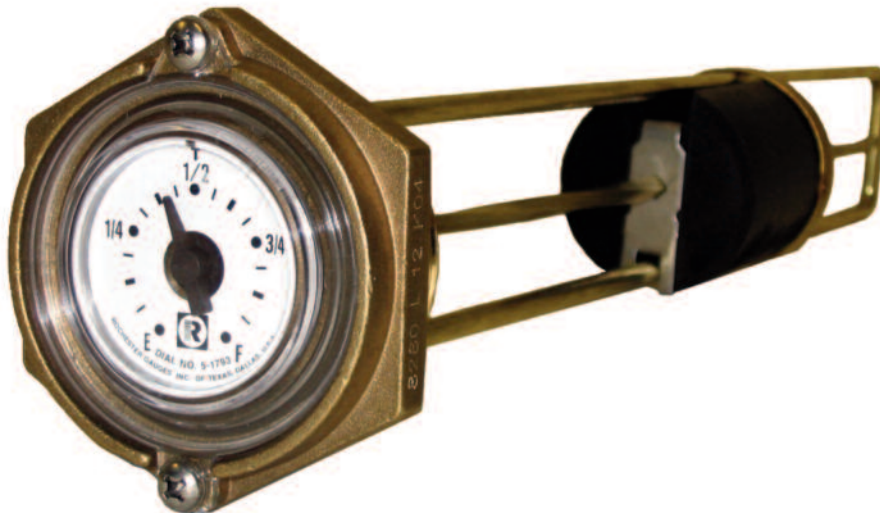

Model #	Sender or Dial Type
8240	Senior, TwinSite™ sender in choice of 0-30, 0-90, 240-30 Ohm ranges. Specify your preference when ordering.
8260	#5097S00570 side-reading Senior fractional dial
8280	#5844S01793 direct-reading Senior fractional dial

See reverse side for dimensional data, materials of construction, performance, and advice on how to order.

01/29/10

The Measure of Excellence

8200

Magnetic Liquid-Level Gauges

[METRIC]

Senior Twinsite™ Sender (Specify Ohm range)

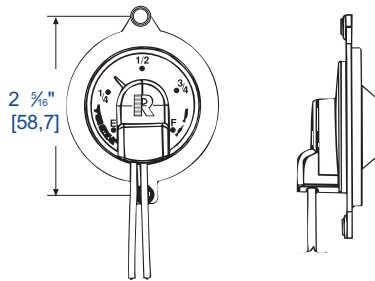

Senior Side-View Dial

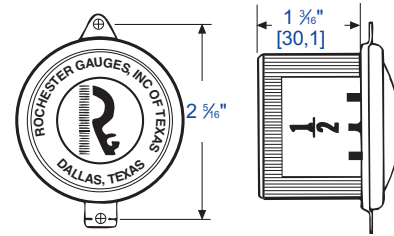

Senior Dial

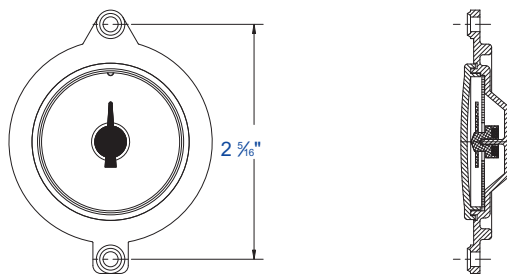

Standard Construction

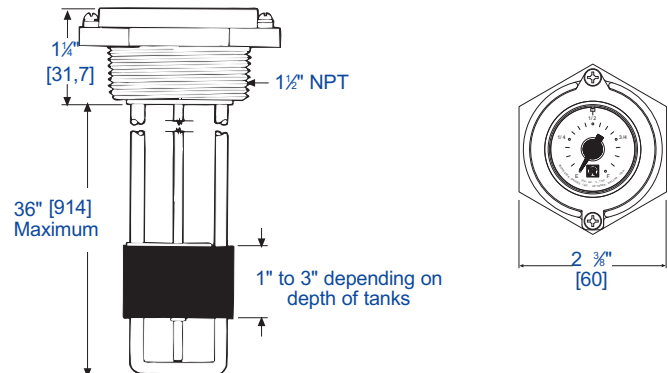

General Specifications*

Mounting

Designed for top mounting only.

Repeatability

Repeatability depends on proper gauge sizing & tank configuration. Normally, standard dials are $\pm 7\%$; side-reading dials are $\pm 8\%$; & Twinsite™ senders are $\pm 12\%$. Vibration improves repeatability.

Temperature

Standard operating range is -40°F to 158°F , -40 to 70C .

Humidity

Exposed portion is fully suitable for marine applications.

Shock

Suitable for marine applications.

Vibration

Suitable for marine applications.

Power

0.5 watts maximum for TwinSite™ versions.

Tank Pressure

0 to 25 PSIG [0 to 1,7 Bar].

Approval

Direct indicating gauge available UL listed for flammable liquids. Some models UL recognized for marine service.

Materials of Construction*

Head, Support Rod, & Centershaft

Brass.

Tie Plate, Guide & Bearing Pin

Stainless steel.

Float

Nitrile rubber.

Drive Magnet

Plated Alnico.

Standard Dial

Polycarbonate, hermetically sealed.

Side-view Dial

Aluminum with polycarbonate crystal, hermetically sealed.

TwinSite™ Sender

Polyamide.

* Materials and specifications are subject to change without notice.

Pressure ratings subject to change due to temperature and other environmental considerations.

When ordering, specify:

1. Gauge model number.
2. Tank height.
3. Ohm range on TwinSite™ versions.
4. Riser height, if any.
5. Any special requirements.