



ISO 9001:2008 CERTIFIED

### Magnetic Liquid-Level Gauges Application

Measures gasoline or diesel fuel levels in tanks on trucks, boats, generators, recreational vehicles, and other applications.

### General Information & Features

These top mounting magnetic liquid-level gauges are built to the high standards of all Rochester designed instruments. The construction permits the replacement of dials when necessary without releasing fumes or liquid to the atmosphere.

Both available dials are fractional and silicone-dampened, and are easily replaced by removing and re-installing two screws. Rochester's rugged gear drive incorporates shrouded, stainless-steel, beveled gears designed to work out any loose particles that might affect gear function. Sealing between the gauge and the tank is achieved through the use of the 0015-00423 Buna-N gasket.

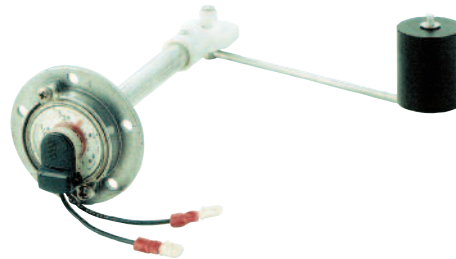

Model 6741 with Twinsite™

Model #	Magnet	Available Dials
6741	Large Alnico	Direct-reading dial or TwinSite™ sender. Choice of 0-30, 0-90, 240-30 Ohms.
6781	Small Alnico	Direct-reading dial only

### Adjustable Liquid-Level Gauges General Information & Features

Adjustable liquid-level gauges are designed for top mounting only. These gauges are equipped with 20.5" [520mm] long float arms which can be cut to fit tank dimensions. Data sheet DS-337 furnishes proper cut lengths and installation instructions for the float and washers (furnished separately). Choice of 0-90, 240-30 ohms.

### Model Selection Chart

Model #	Dial Used	Gasket Used
6741-00183	None	0015-00423
6741-00290	P5744S02541	
6741-00333		Not furnished
6781-00248	5323S01834	0015-00423

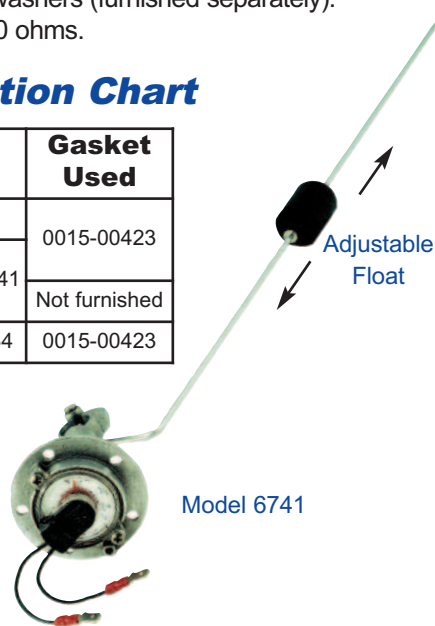

Tank Depth in Inches	Distance From Float Bend to Float Rod Cut-off point
6	3"
7	3 3/4"
8	4 5/8"
9	5 3/8"
10	6 1/8"
11	7 1/8"
12	8 5/8"
13	9 3/4"
14	10 3/8"
15	11 3/8"
16	12 3/4"
17	13 3/4"
18	14 1/8"
19	15 1/8"
20	16 1/8"
21	17 1/8"
22	18 1/8"
23	20"
24	21"
25	22"
26	23"
27	24"
28	25 1/8"
29	26 1/8"
30	27 1/8"
31	28 1/8"
32	29 1/8"
33	30 1/4"
34	31 1/4"
35	32 1/4"
36	33 1/4"

Magnetic & Adjustable Liquid-Level Gauges

## 6700 Series

# Magnetic Liquid-Level Gauges

Standard direct-reading gauge with 5323S01792 dial

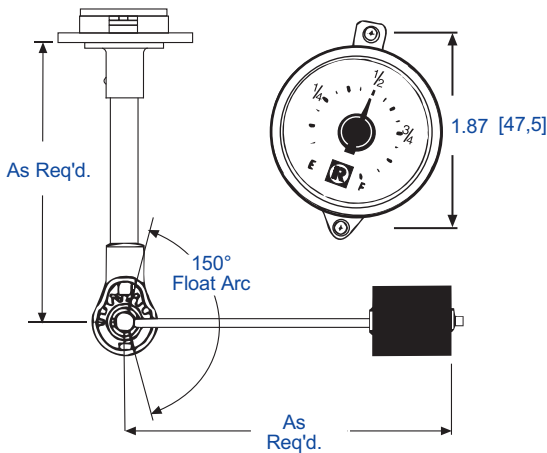

## Adjustable Liquid-Level Gauges

Direct reading gauge with 5323S01834 dial

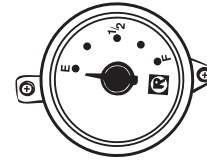

**TwinSite™ Dial, 0-90 ohms & 240-30 ohms**

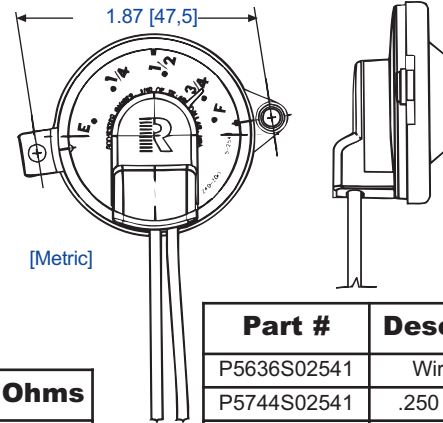

**Twinsite™ Dial, 0-30 ohms, 0-90 ohms & 240-30 ohms**

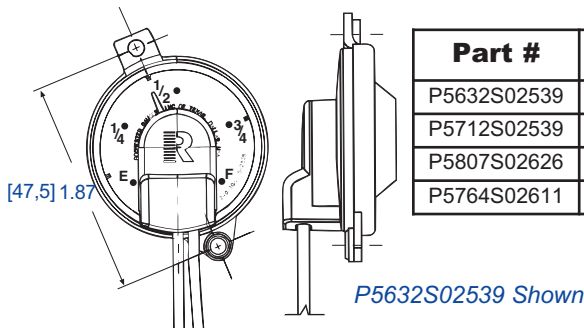

Part #	Description	Ohms
P5632S02539	Wire Leads	240-30
P5712S02539	.250 Male Tab	
P5807S02626	Wire Leads	0-90
P5764S02611	.250 Male Tab	0-30

Part #	Description	Ohms
P5636S02541	Wire Leads	240-30
P5744S02541	.250 Male Tab	
P5872S02684	Wire Leads	0-90

## General Specifications\*

### Mounting

Recommended for top-mounting only.

### Accuracy

Depends on proper sizing of gauge and tank configuration. Normally  $\pm 5\%$  on direct-reading dial,  $\pm 7\%$  on TwinSite™ dial.

### Temperature Range

Standard range is  $-40^{\circ}\text{F}$  to  $158^{\circ}\text{F}$ ,  $-40\text{C}$  to  $70\text{C}$ .

### Humidity

For high humidity and marine applications, painting of gauge, less dial, is recommended.

### Shock

Suitable for mobile applications.

### Vibration

Suitable for mobile applications.

### Power

0.5 watts maximum for TwinSite™ versions.

### Tank Pressure

0 to 10 psig [0 to 0,68 Bar]

### Approvals

Some models are UL recognized for marine service. Some models are UL listed for flammable fluids. Passes BIA fire test.

Note: For installation instructions see MS-514 (mounting standard).

## Materials of Construction\*

### Head

Diecast aluminum with standard SAE gasoline gauge flange ( $2\frac{1}{8}$ " [54 mm] bolt circle for 5 #10 screws, screws not furnished).

### Centershaft, Support Tube & Float Rod

Tempered aluminum

### Gears, Cross Stud & Bearings

Stainless steel

### Drive Magnet

Nickel-plated alnico

### Gear Housing

Acetal plastic or zinc

### Float

Nitrile rubber

### Gasket

Buna-N

### Direct-Reading Dial

Hermetically sealed polycarbonate

### TwinSite™ Sender

Polyamide

\* Materials and specifications are subject to change without notice.

Pressure ratings subject to change due to temperature and other environmental considerations.

## When ordering, specify:

1. Gauge model number.
2. Tank depth.
3. Float orientation, 3 o'clock standard.
4. Details of any optional features.

01/20/10